



STREND PRO[®]

G A R D E N

SK

Návod na použitie a montáž

CZ

Návod k použití a montáži

HU

Használati és összeszerelési útmutató

RO

Instrucțiuni de utilizare și asamblare









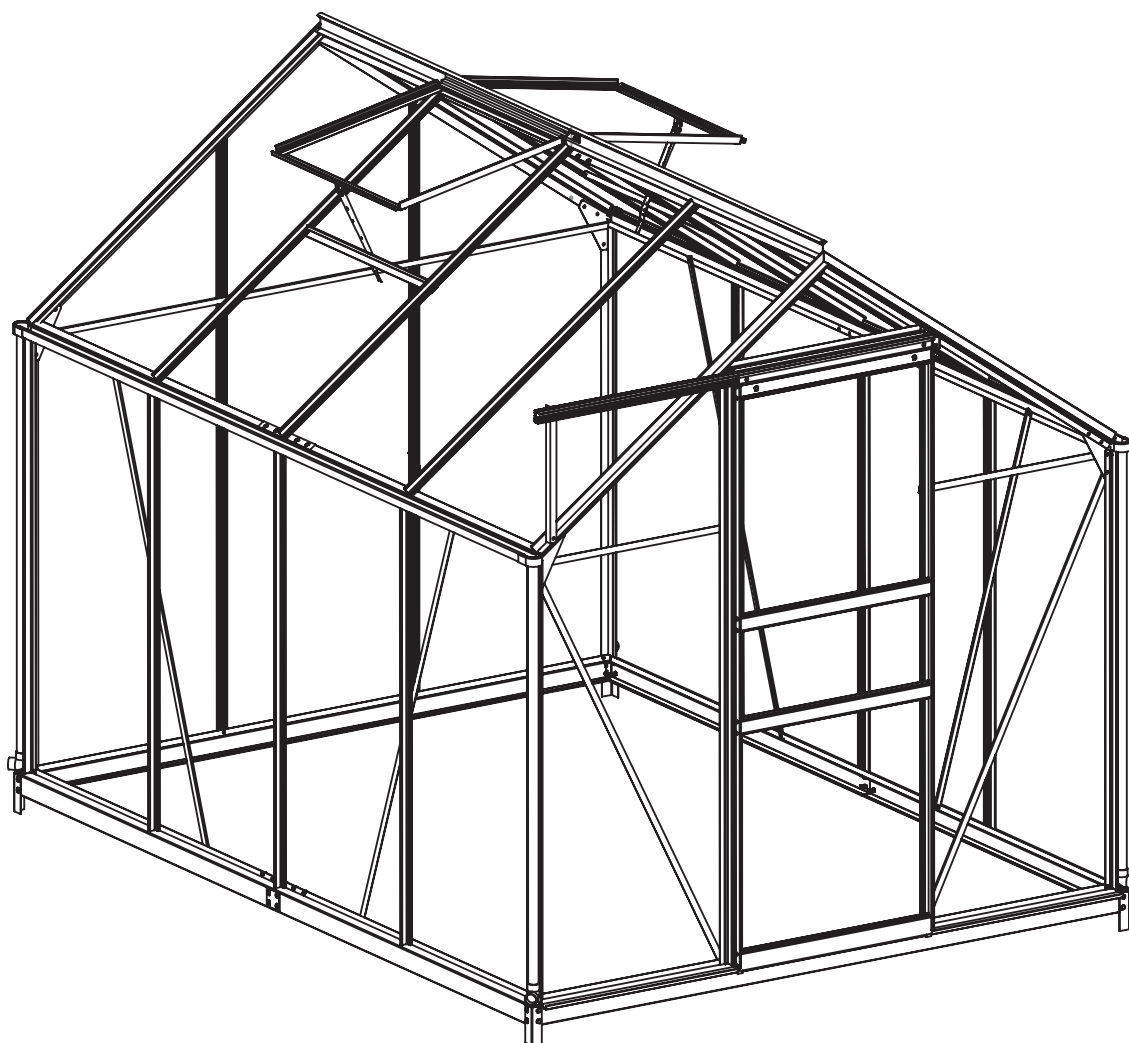

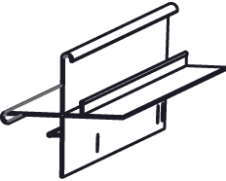
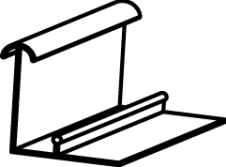
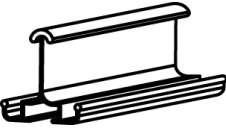
EN





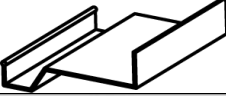

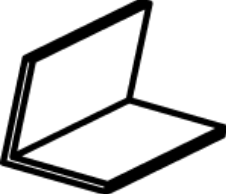



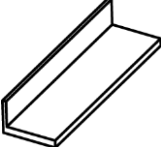
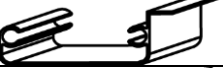

Instructions for use and assembly



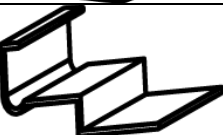





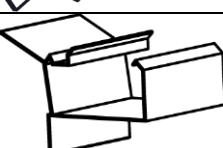
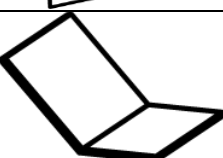
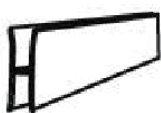
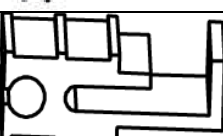

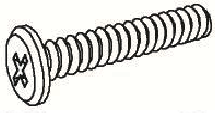
DE

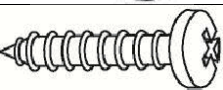
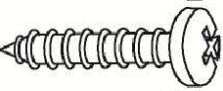
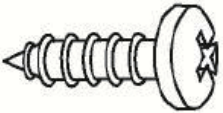

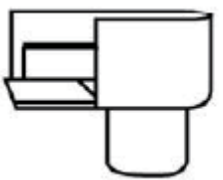
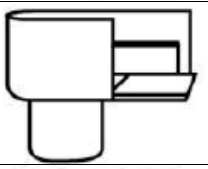
Gebrauchs- und Montageanleitung

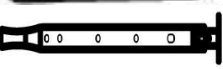
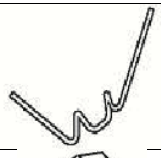
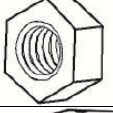



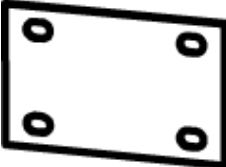

SK	Č. výr.	Obrázok	Množstvo	Rozmery (mm)
CZ	Č. výr.	Obrázek	Množství	Rozměry (mm)
HU	Cikkszám	Ábra	Mennyiség	Méret(mm)
RO	Nr. Art.	Imagine	Cantitate	Dimensiuni (mm)
EN	Product no.	Image	Quantity	Dimensions (mm)
DE	Art. Nr.	Abbildung	Menge	Abmessung (mm)
	1		4	1215
	2		1	1134
	3		1	1134
	4		1	1134
	5		1	1134
	6		1	1647
	7		1	1647
	8		1	1670
	9		1	1670
	10		6	1215
	11		6	1114
	12		1	610
	13		4	
	14		1	1260
	15		2	634
	16		1	1822
	17		1	1822
	18		1	
	19		1	380
	20		2	1608

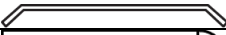
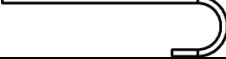
21		1	1814
22		4	1304
23		2	594
24		1	610
25		2	1304
26		2	610
27		1	610
28		4	520
29		1	608
30		2	595
31		2	595
32A		2	1519
32B		2	911
32C		2	170
33		1	1519
33C		1	170
33D		1	911
34A		2	1522
34B		2	914
34C		2	170
35		5	
36		2	

37		1	
38		1	
39		2	
40		165	
41		14	
41A		2	
42		8	
43		18	
44A		2	
44B		2	
45A		1	
45B		1	
46		2	
47		146	
48		166	
49		4	
50		2	
51		4	

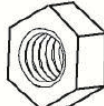
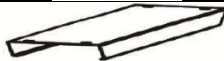

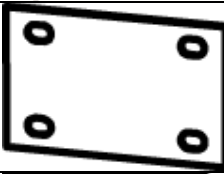

52		2	
53		44	
54		1	
55		8	

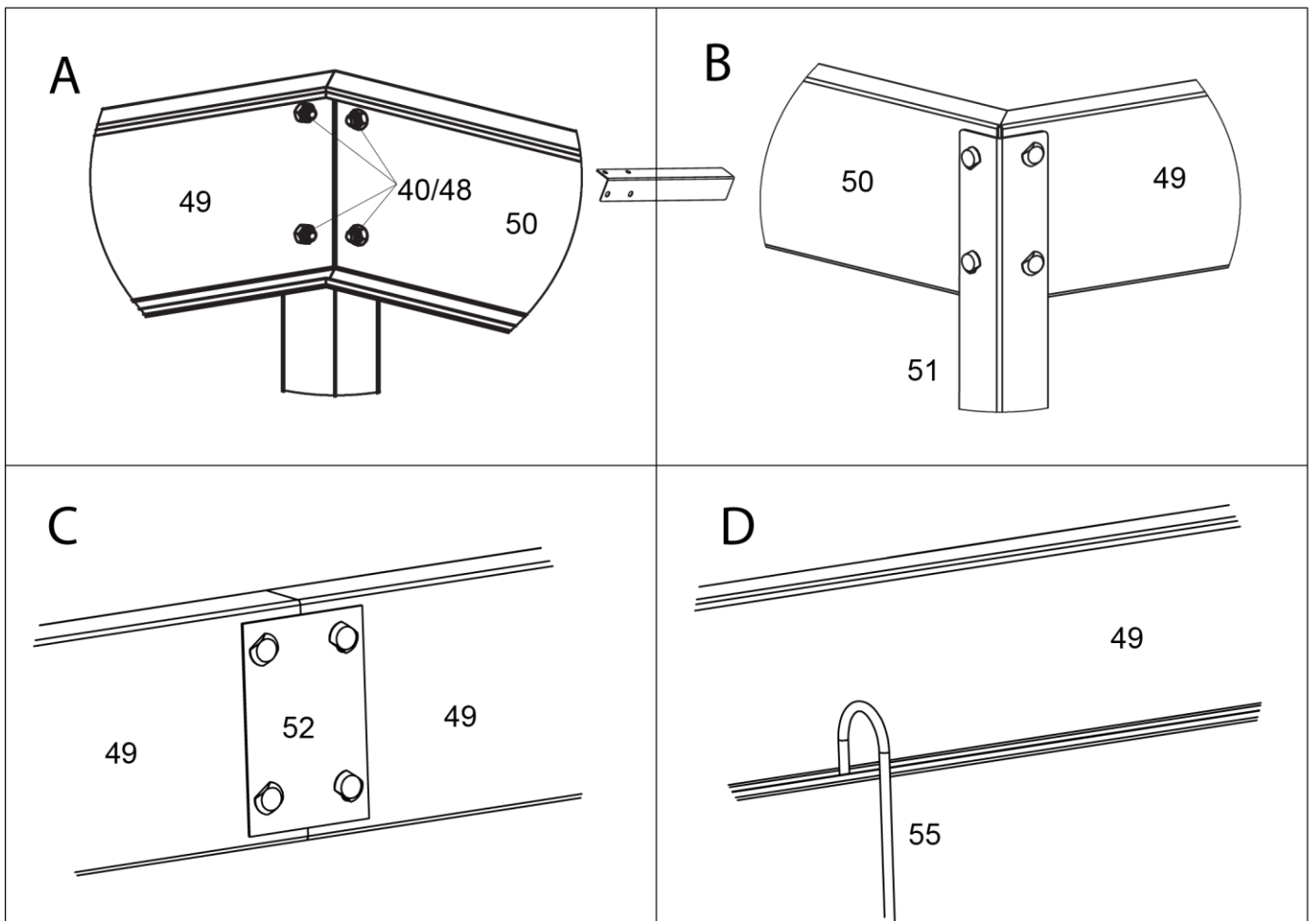
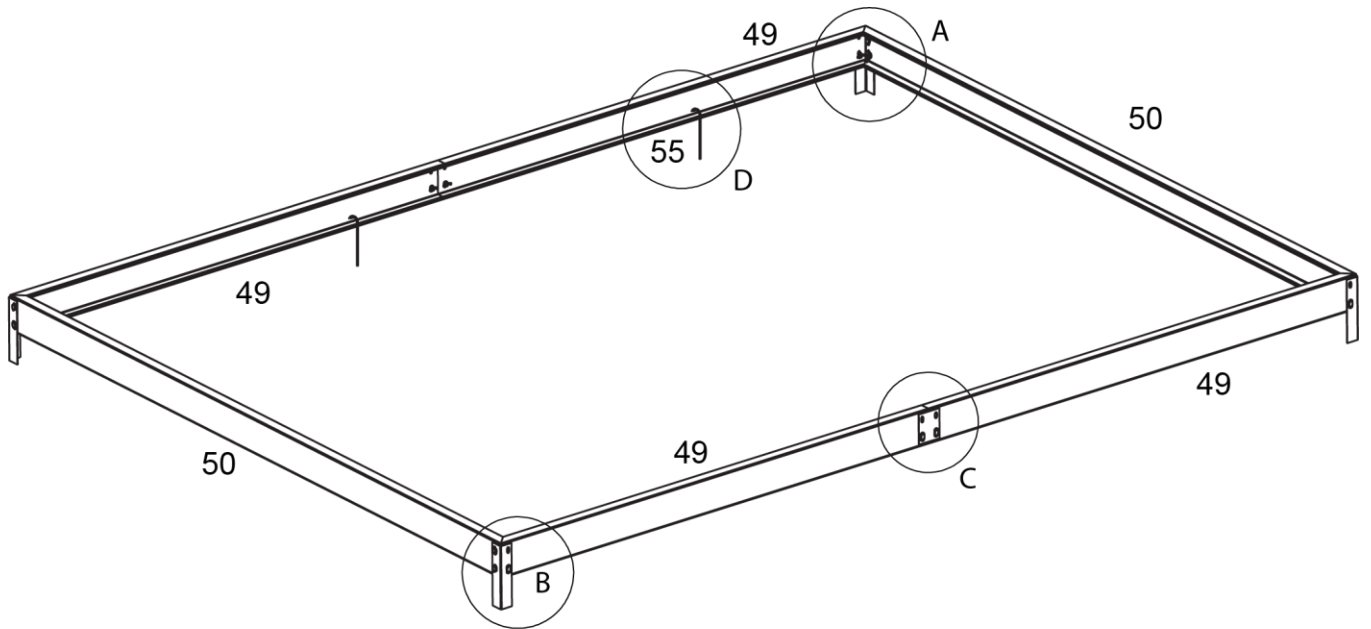
**MONTÁŽ ZÁKLADNE / MONTÁŽ ZÁKLADNY / ALAP SZERELÉSE / MONTAREA BAZEI /
BASE INSTALLATION / AUFBAU DES FUNDAMENTES**

SK	Č. výr.	Obrázok	Množstvo
CZ	Č. výr.	Obrázek	Množství
HU	Cikkszám	Ábra	Mennyiség
RO	Nr. Art.	Imagine	Cantitate
EN	Product no.	Image	Quantity
DE	Art. Nr.	Abbildung	Menge
	40		24
	48		24
	49		4
	50		2
	51		4
	52		2
	55		8



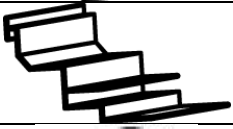

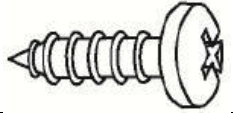
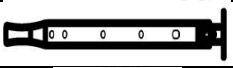
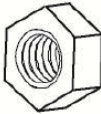
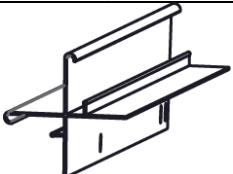

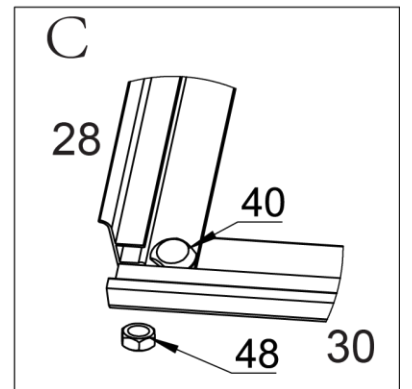
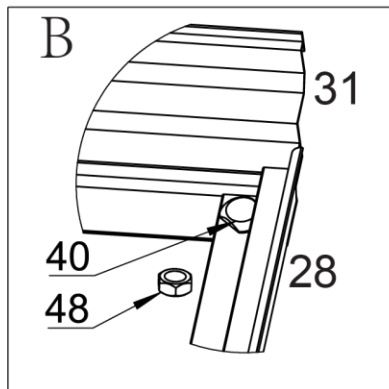
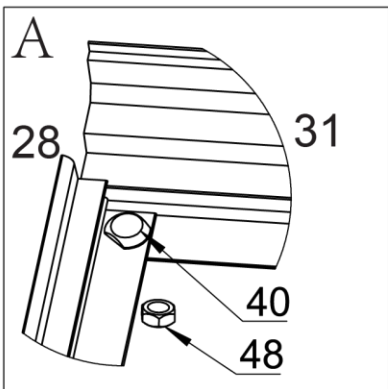
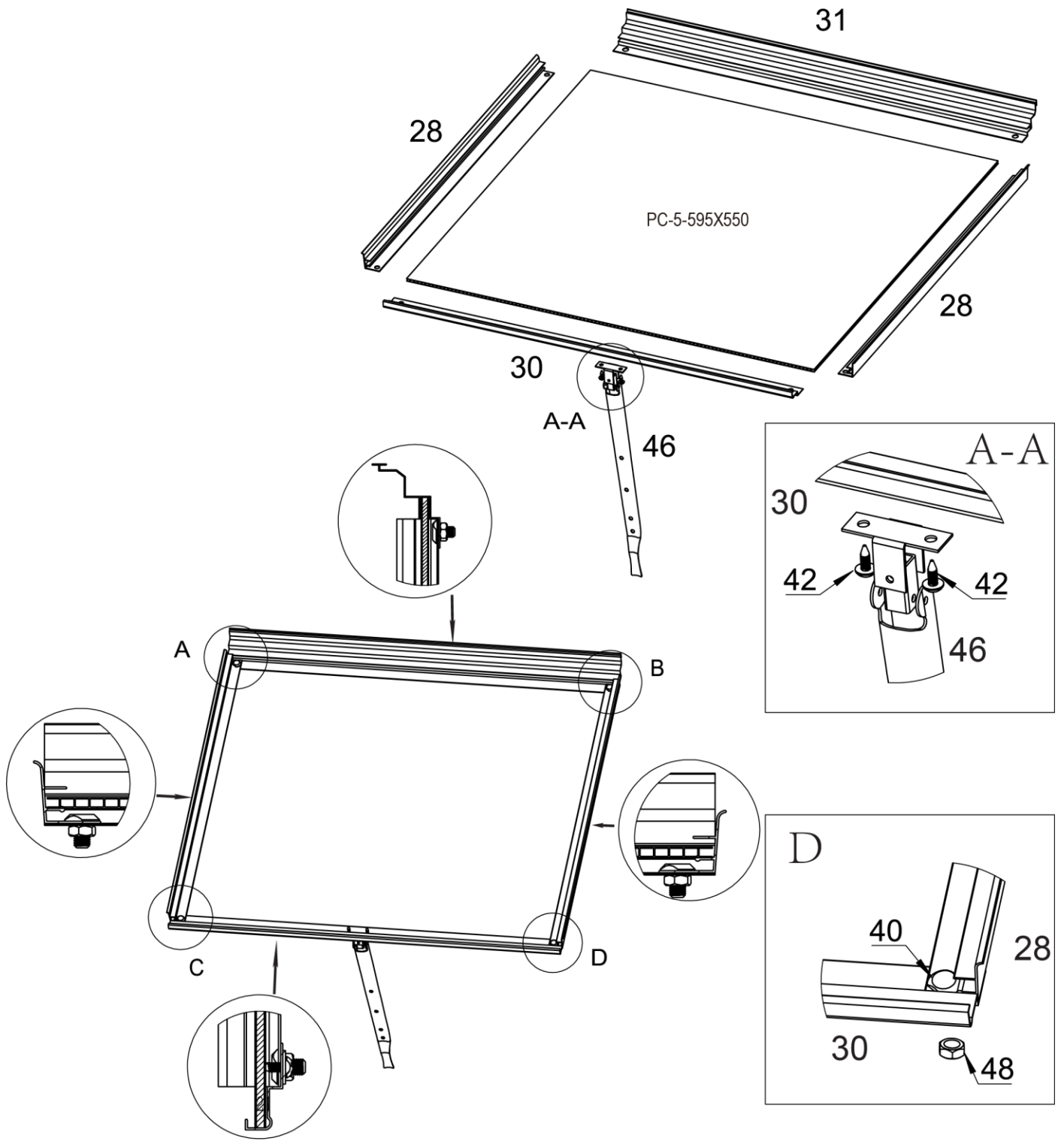



**MONTÁŽ OKNA / MONTÁŽ OKNA / ABLAK SZERELÉSE / MONTAREA FERESTREI /
WINDOW INSTALLATION / AUFBAU DES FENSTERS**

SK	Č. výr.	Obrázok	Množstvo	Rozmery (mm)
CZ	Č. výr.	Obrázek	Množství	Rozměry (mm)
HU	Cikkszám	Ábra	Mennyiség	Méret(mm)
RO	Nr. Art.	Imagine	Cantitate	Dimensiuni (mm)
EN	Product no.	Image	Quantity	Dimensions (mm)
DE	Art. Nr.	Abbildung	Menge	Abmessung (mm)
	28		4	520
	30		2	595
	31		2	595
	40		8	
	42		4	
	46		2	
	48		8	
	5		2	595 x 550

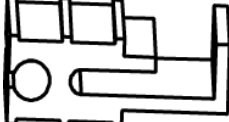

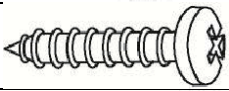



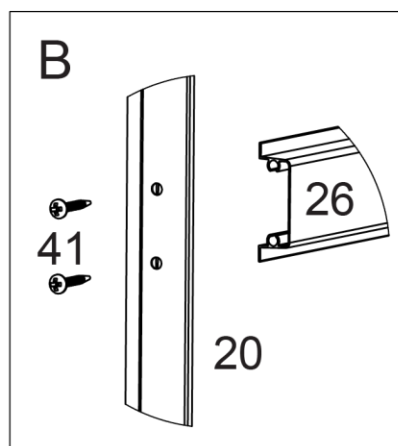
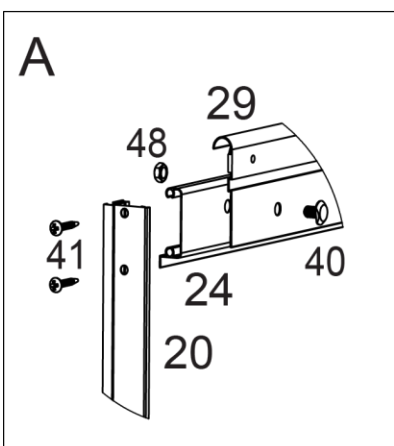
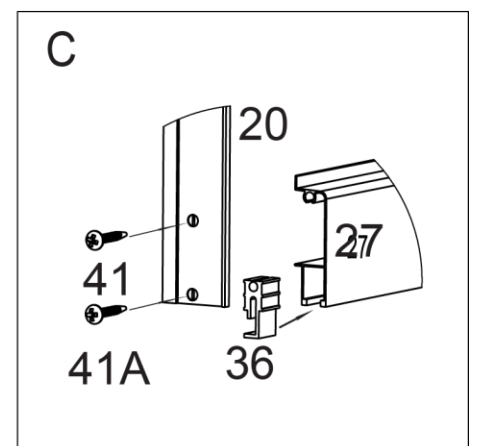
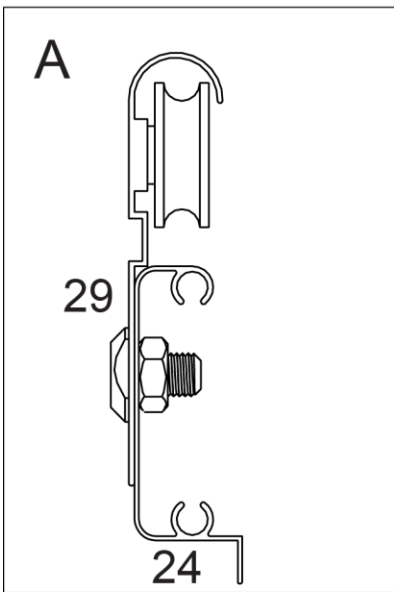
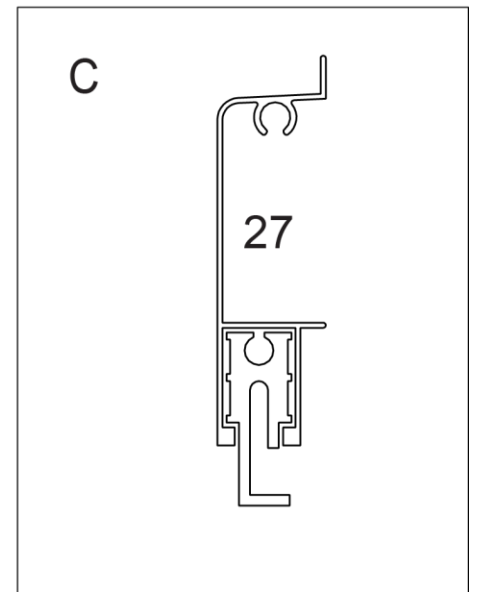
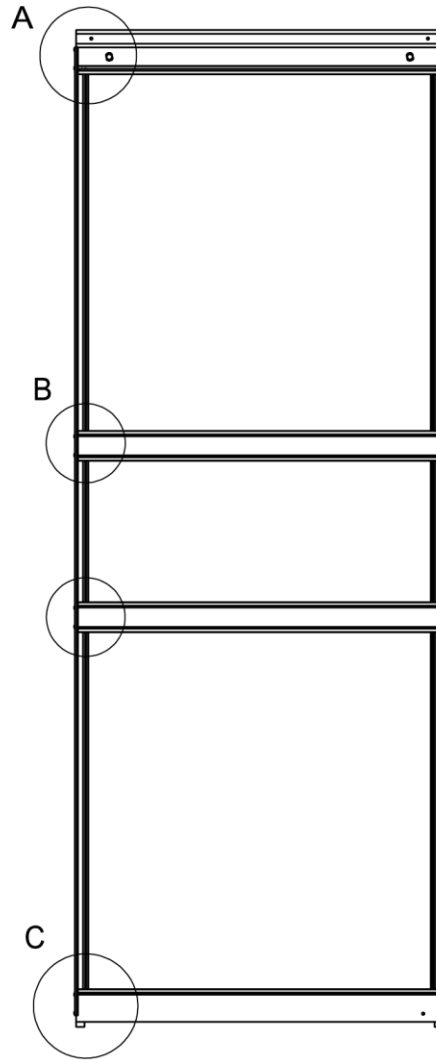
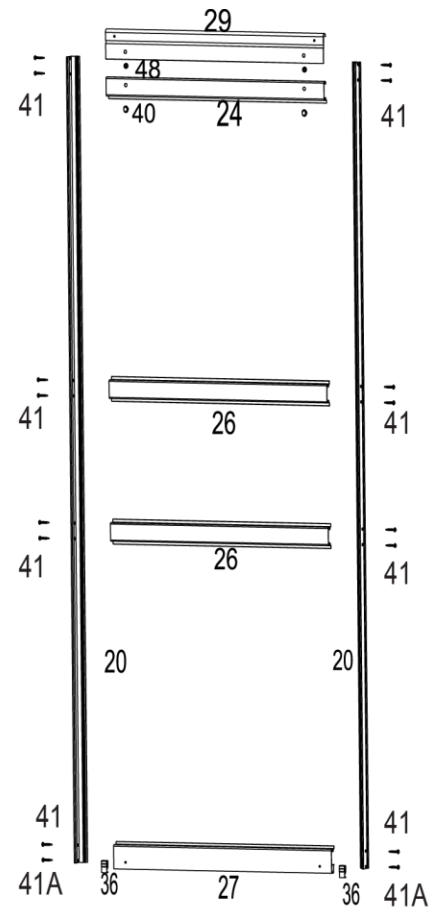

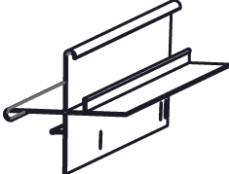
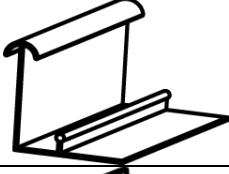
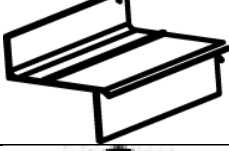

**MONTÁŽ DVERÍ / MONTÁŽ DVEŘÍ / AJTÓ SZERELÉSE / MONTAREA UȘII /
DOOR INSTALLATION / AUFBAU DER TÜR**

SK	Č. výr.	Obrázok	Množstvo	Rozmery (mm)
CZ	Č. výr.	Obrázek	Množství	Rozměry (mm)
HU	Cikkszám	Ábra	Mennyiség	Méret(mm)
RO	Nr. Art.	Imagine	Cantitate	Dimensiuni (mm)
EN	Product no.	Image	Quantity	Dimensions (mm)
DE	Art. Nr.	Abbildung	Menge	Abmessung (mm)
	20		2	1608
	24		1	610
	26		2	610
	27		1	610
	29		1	608
	36		2	
	40		2	
	41		14	
	41A		2	
	48		2	

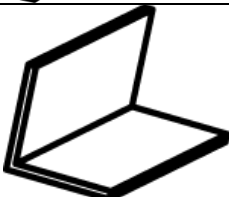
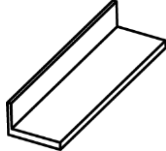

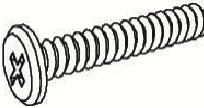

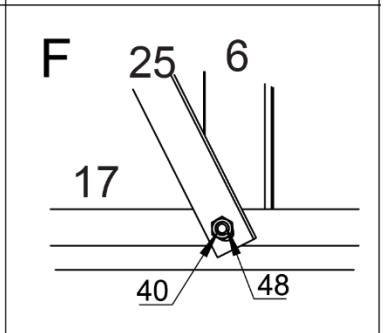
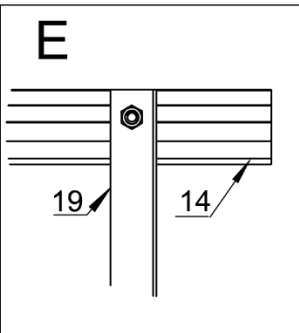
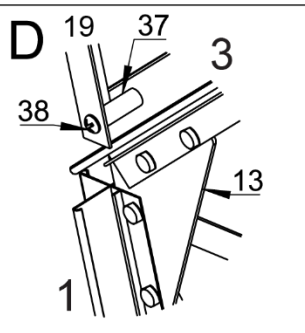
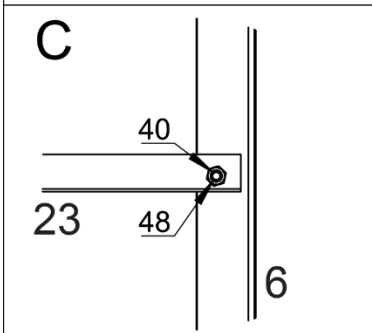
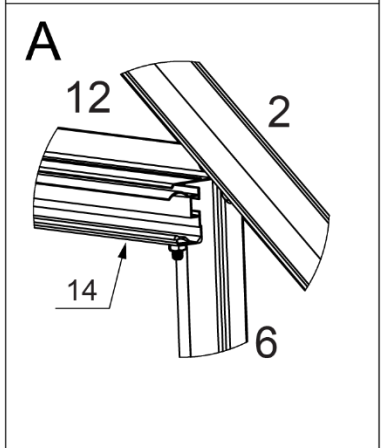
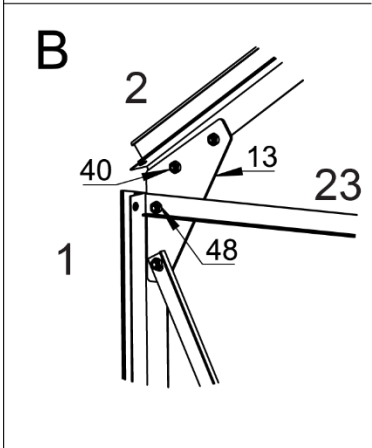
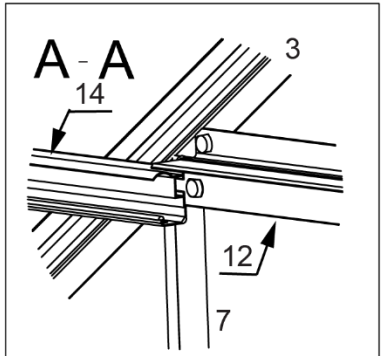
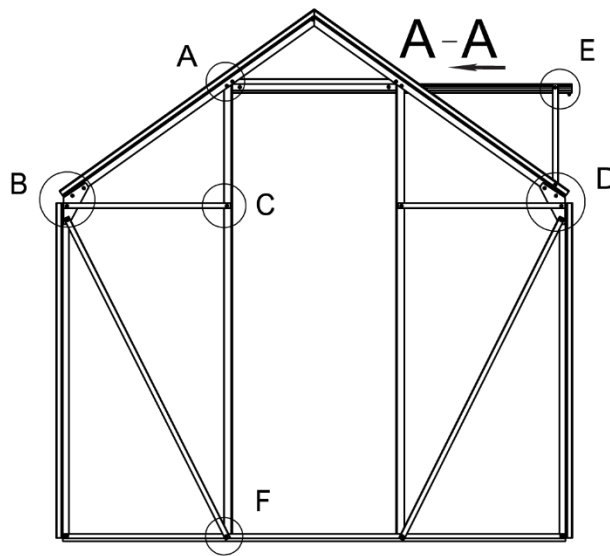
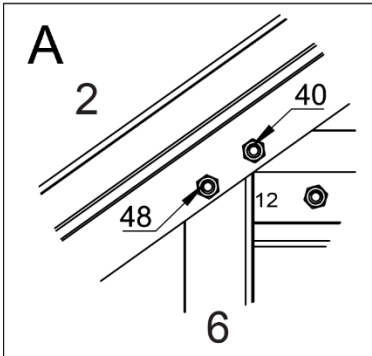
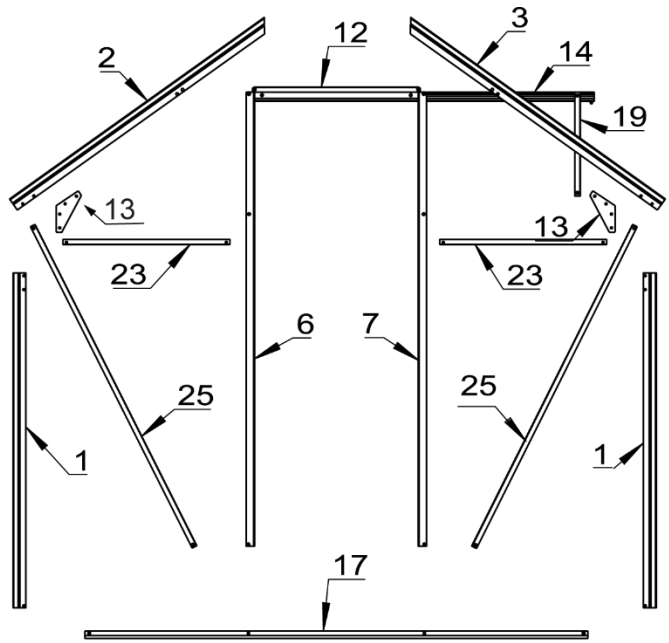

**MONTÁŽ PREDNEJ STENY / MONTÁŽ PŘEDNÍ STĚNY / ELÜLSŐ FAL SZERELÉSE /
MONTAREA PERETELUI DIN FAȚĂ / FRONT WALL INSTALLATION /
AUFBAU DES VORDERSEITE**

SK	Č. výr.	Obrázok	Množstvo	Rozmery (mm)
CZ	Č. výr.	Obrázek	Množství	Rozměry (mm)
HU	Cikkszám	Ábra	Mennyiség	Méret(mm)
RO	Nr. Art.	Imagine	Cantitate	Dimensiuni (mm)
EN	Product no.	Image	Quantity	Dimensions (mm)
DE	Art. Nr.	Abbildung	Menge	Abmessung (mm)
	1		2	1215
	2		1	1134
	3		1	1134
	6		1	1647
	7		1	1647
	12		1	610
	13		2	
	14		1	1260
	17		1	1822
	19		1	380
	23		2	594
	25		2	1304
	37		1	
	38		1	
	40		21	
	48		22	

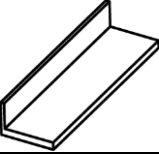

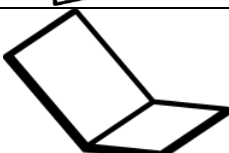

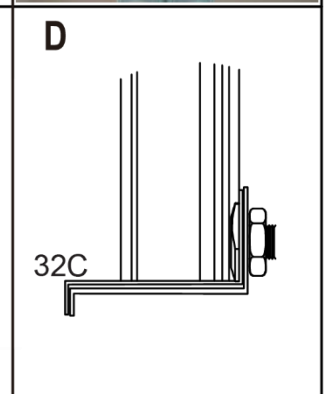
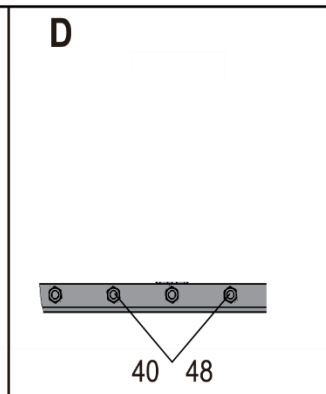
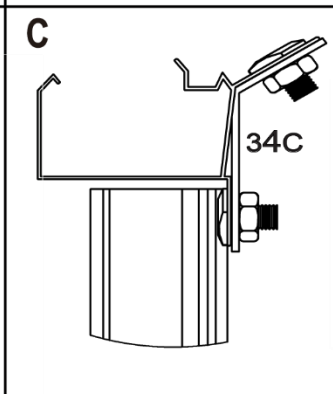
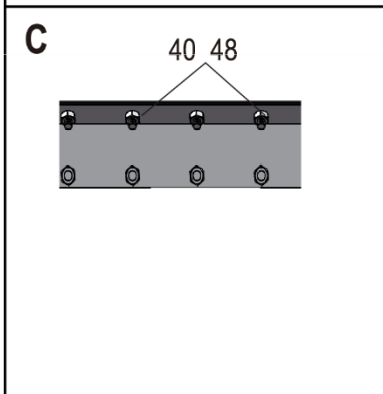
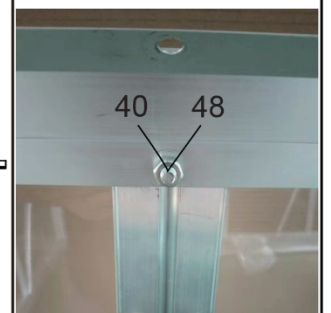
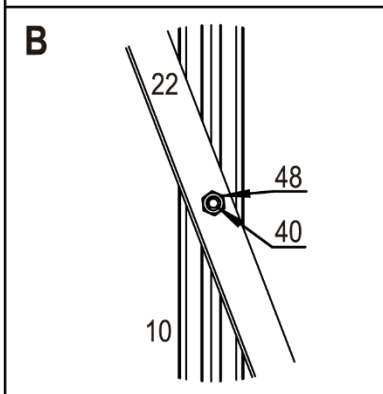
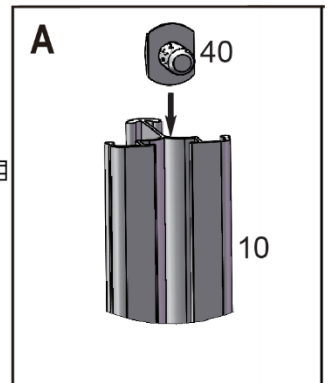
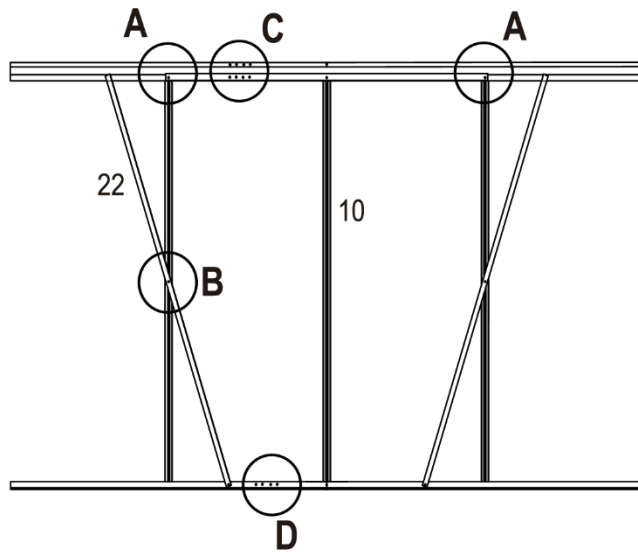
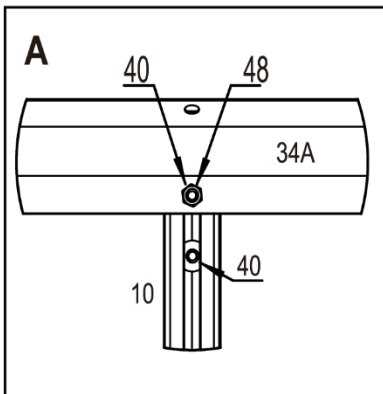
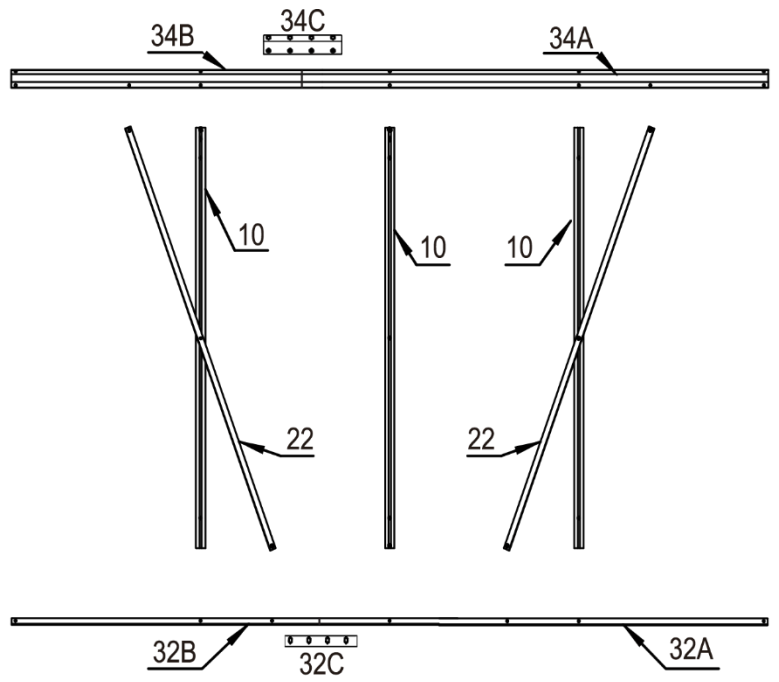

**MONTÁŽ BOČNEJ STENY / MONTÁŽ BOČNÍ STĚNY / OLDALFAL SZERELÉSE /
MONTAREA PERETELUI LATERAL / SIDE WALL INSTALLATION / AUFBAU DER SEITENWAND**

SK	Č. výr.	Obrázok	Množstvo	Rozmery (mm)
CZ	Č. výr.	Obrázek	Množství	Rozměry (mm)
HU	Cikkszám	Ábra	Mennyiség	Méret(mm)
RO	Nr. Art.	Imagine	Cantitate	Dimensiuni (mm)
EN	Product no.	Image	Quantity	Dimensions (mm)
DE	Art. Nr.	Abbildung	Menge	Abmessung (mm)
	10		6	1215
	22		4	1304
	32A		2	1519
	32B		2	911
	32C		2	214
	34A		2	1522
	34B		2	914
	34C		2	170
	40		50	
	48		50	

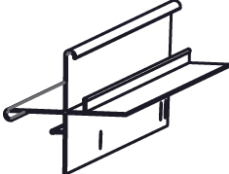
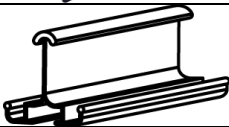

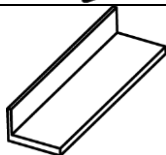

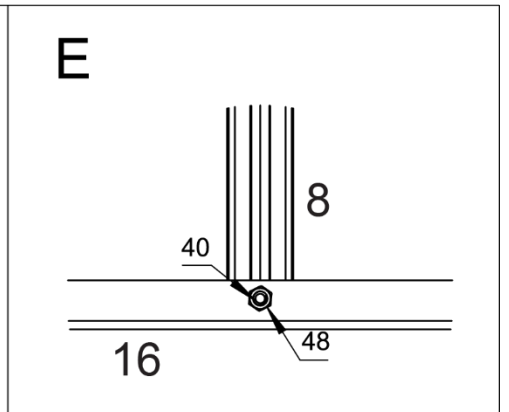
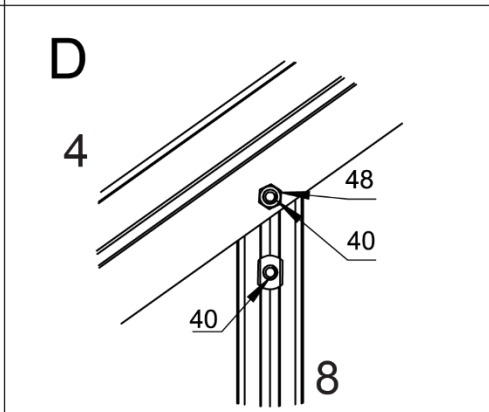
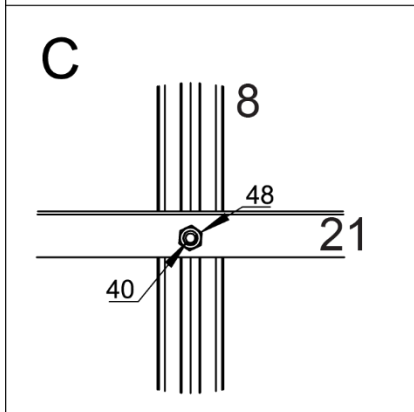
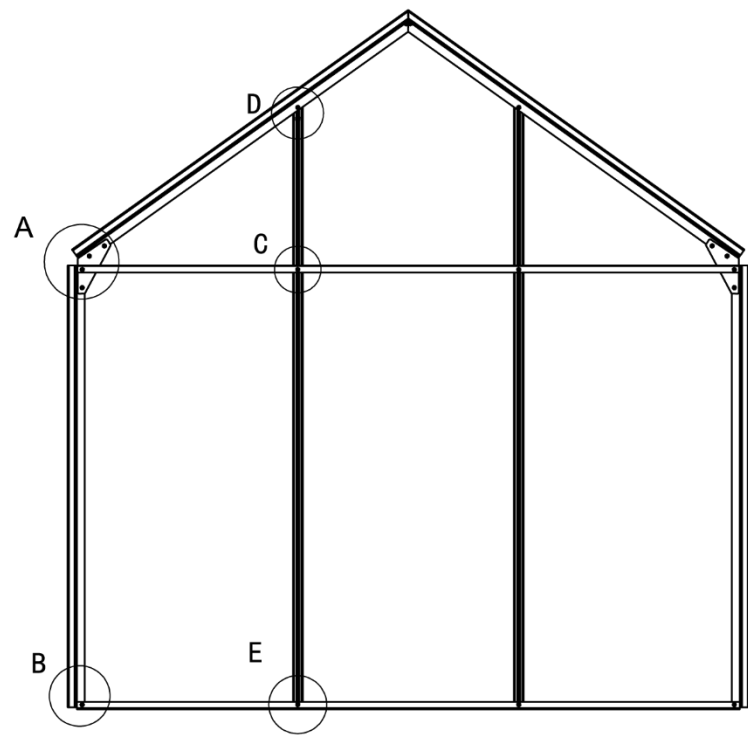
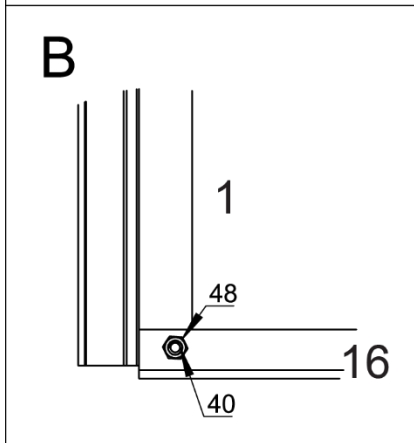
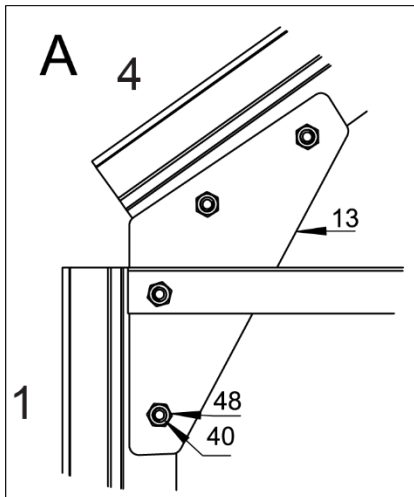
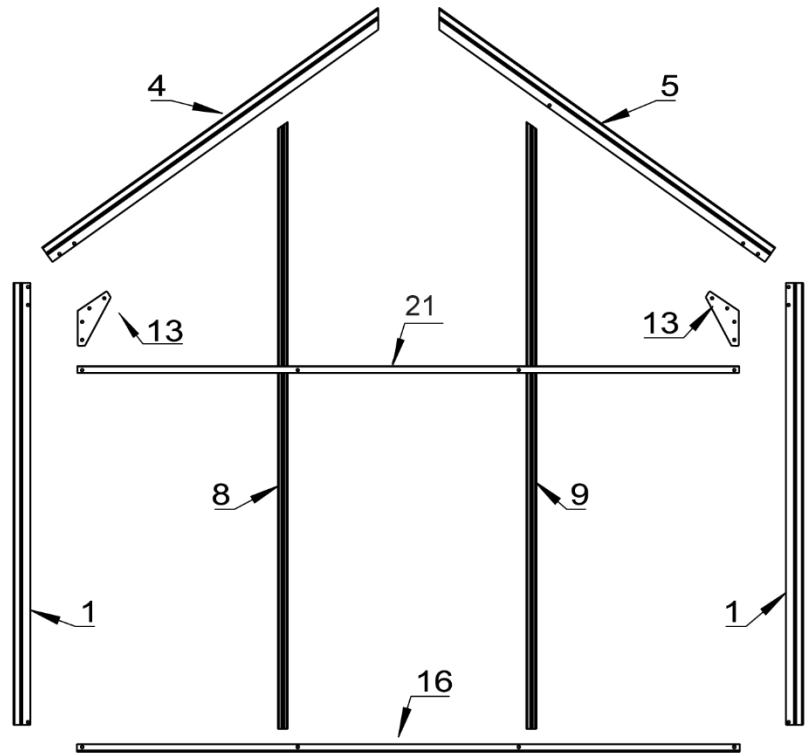

**MONTÁŽ ZADNEJ STENY / MONTÁŽ ZADNÍ STĚNY / HÁTSÓ FAL SZERELÉSE /
MONTAREA PERETELUI DIN SPATE / BACK WALL INSTALLATION /
AUFBAU DER RÜCKWAND**

SK	Č. výr.	Obrázok	Množstvo	Rozmery (mm)
CZ	Č. výr.	Obrázek	Množství	Rozměry (mm)
HU	Cikkszám	Ábra	Mennyiség	Méret(mm)
RO	Nr. Art.	Imagine	Cantitate	Dimensiuni (mm)
EN	Product no.	Image	Quantity	Dimensions (mm)
DE	Art. Nr.	Abbildung	Menge	Abmessung (mm)
	1		2	1215
	4		1	1134
	5		1	1134
	8		1	1670
	9		1	1670
	13		2	
	16		1	1822
	21		1	1814
	40		16	
	48		16	

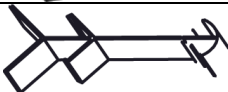

**MONTÁŽ VŠETKÝCH RÁMOVÝCH STIEN / MONTÁŽ VŠECH RÁMOVÝCH STĚN /
AZ ÖSSZES KERETES FAL SZERELÉSE / MONTAREA TUTUROR PEREȚILOR CADRU /
INSTALLATION OF ALL FRAME WALLS / ZUSAMMENBAU ALLER RAHMENWÄMDE**

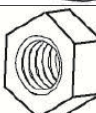
SK	Č. výr.	Obrázok	Množstvo	Rozmery (mm)
CZ	Č. výr.	Obrázek	Množství	Rozměry (mm)
HU	Cikkszám	Ábra	Mennyiség	Méret(mm)
RO	Nr. Art.	Imagine	Cantitate	Dimensiuni (mm)
EN	Product no.	Image	Quantity	Dimensions (mm)
DE	Art. Nr.	Abbildung	Menge	Abmessung (mm)
	33		2	1519
	33C		1	170
	33D		1	911
	40		28	
	48		28	

SK Upozornenie:

Matica a komponent 33D sa nachádzajú oproti oknu

CZ Upozornění:

Matice a komponent 33D jsou naproti oknu

HU Figyelmeztetés:

Az anya és a 33D elem az ablakkal szemben található

RO Atenționare:

Piulița și componenta 33D se află față în față cu fereastra

EN Hint:







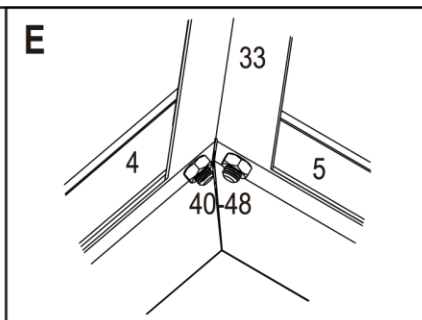
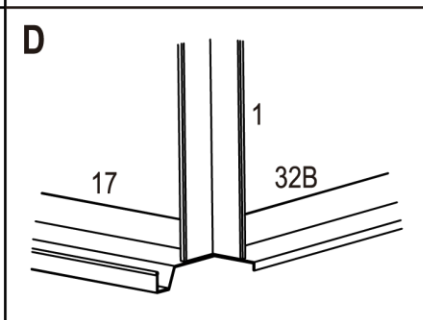
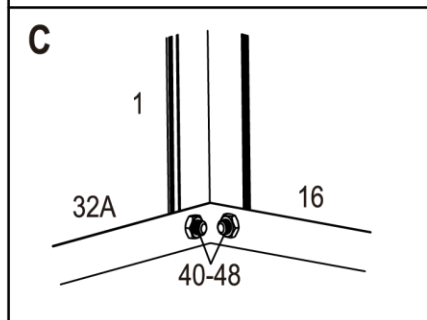
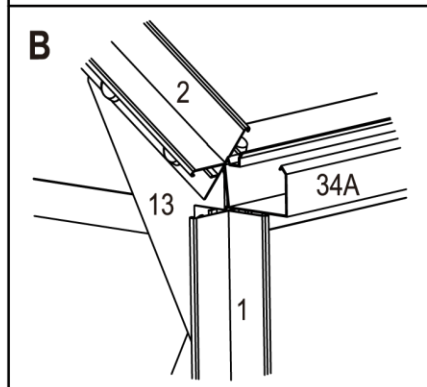
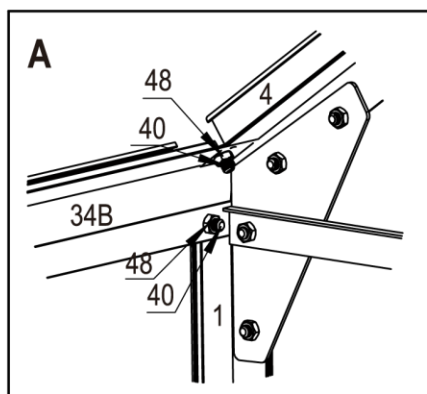
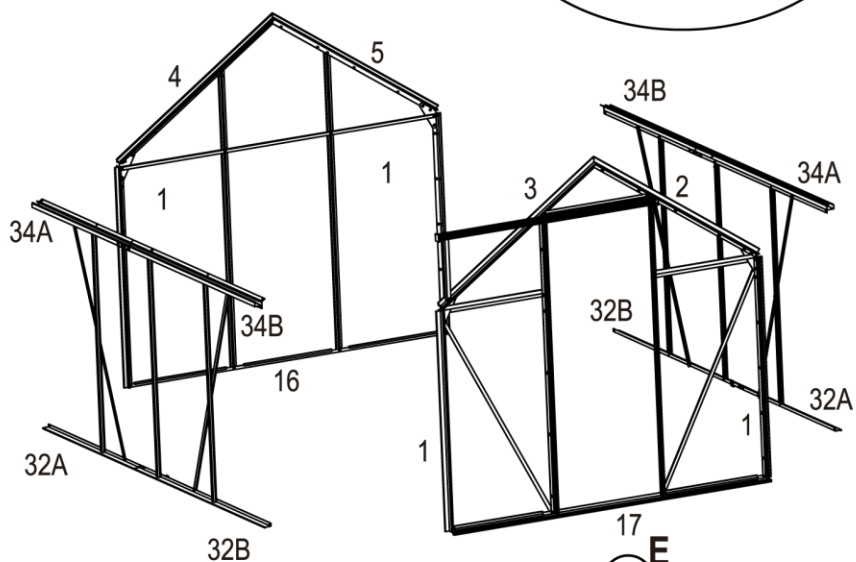
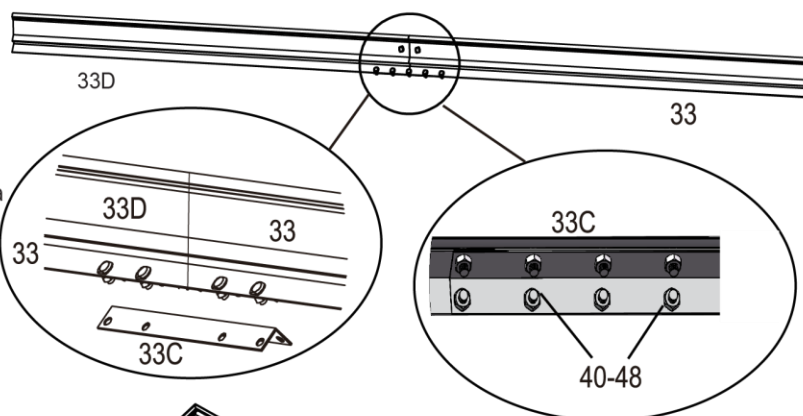

The nut and component 33D are positioned opposite the window

DE Hinweis:

Mutter und 33D befinden sich gegenüber dem Fenster

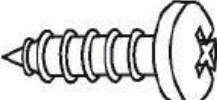





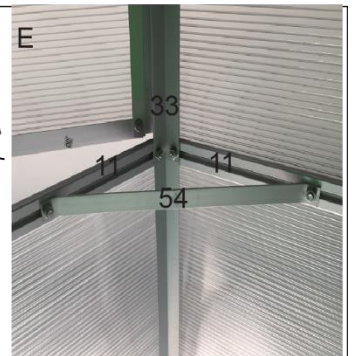
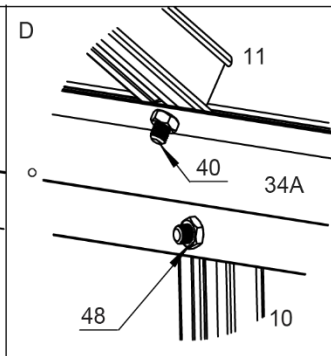
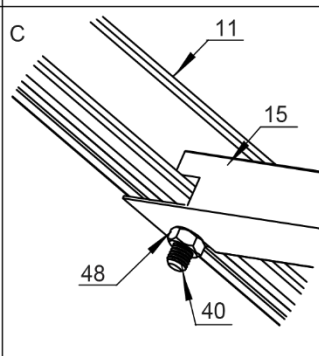
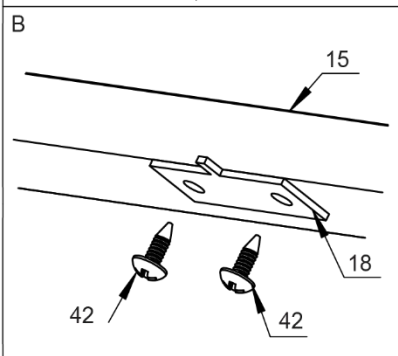
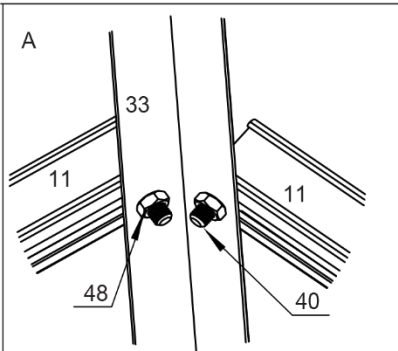
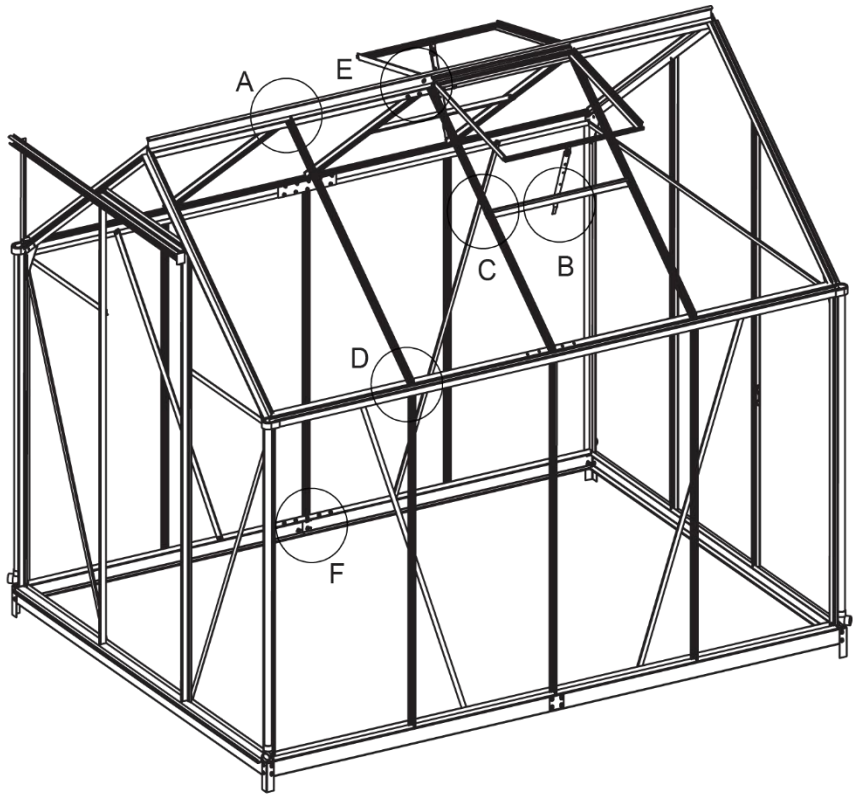





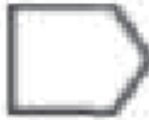

**MONTÁŽ BOČNEJ STENY / MONTÁŽ BOČNÍ STĚNY / OLDALFAL SZERELÉSE /
MONTAREA PERETELUI LATERAL / SIDE WALL INSTALLATION / AUFBAU DER SEITENWAND**

SK	Č. výr.	Obrázok	Množstvo	Rozmery (mm)
CZ	Č. výr.	Obrázek	Množství	Rozměry (mm)
HU	Cikkszám	Ábra	Mennyiség	Méret(mm)
RO	Nr. Art.	Imagine	Cantitate	Dimensiuni (mm)
EN	Product no.	Image	Quantity	Dimensions (mm)
DE	Art. Nr.	Abbildung	Menge	Abmessung (mm)
	11		6	1114
	15		1	634
	18		1	
	40		12	
	42		2	
	43		18	
	48		12	
	54		1	

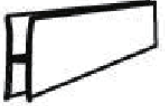
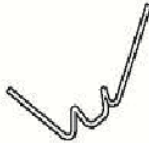

**UPEVNENIE PRIEHĽADNÝCH PC PANELOV / UPEVNĚNÍ PRŮHLEDNÝCH PC PANELŮ /
AZ ÁTTETSZŐ PC PANELEK RÖGZÍTÉSE / FIXAREA PANOURILOR TRANSPARENTE PC /
FIXING TRANSPARENT PC PANELS / ANBRINGEN DER TRANSPARENTE PC PANELE**

SK	Č. výr.	Obrázok	Množstvo	Rozmery (mm)
CZ	Č. výr.	Obrázek	Množství	Rozměry (mm)
HU	Cikkszám	Ábra	Mennyiség	Méret(mm)
RO	Nr. Art.	Imagine	Cantitate	Dimensiuni (mm)
EN	Product no.	Image	Quantity	Dimensions (mm)
DE	Art. Nr.	Abbildung	Menge	Abmessung (mm)
	1		13	605 x 1212
	2		6	605 x 1130
	3A		2	605 x 455
	3B		2	605 x 455
	4		2	605 x 585
	5		2	595 x 550
	6		1	605 x 675
	7		1	605 x 250
	8		1	615 x 241
	9		2	605 x 602
	35		5	
	47		146	
	53		44	

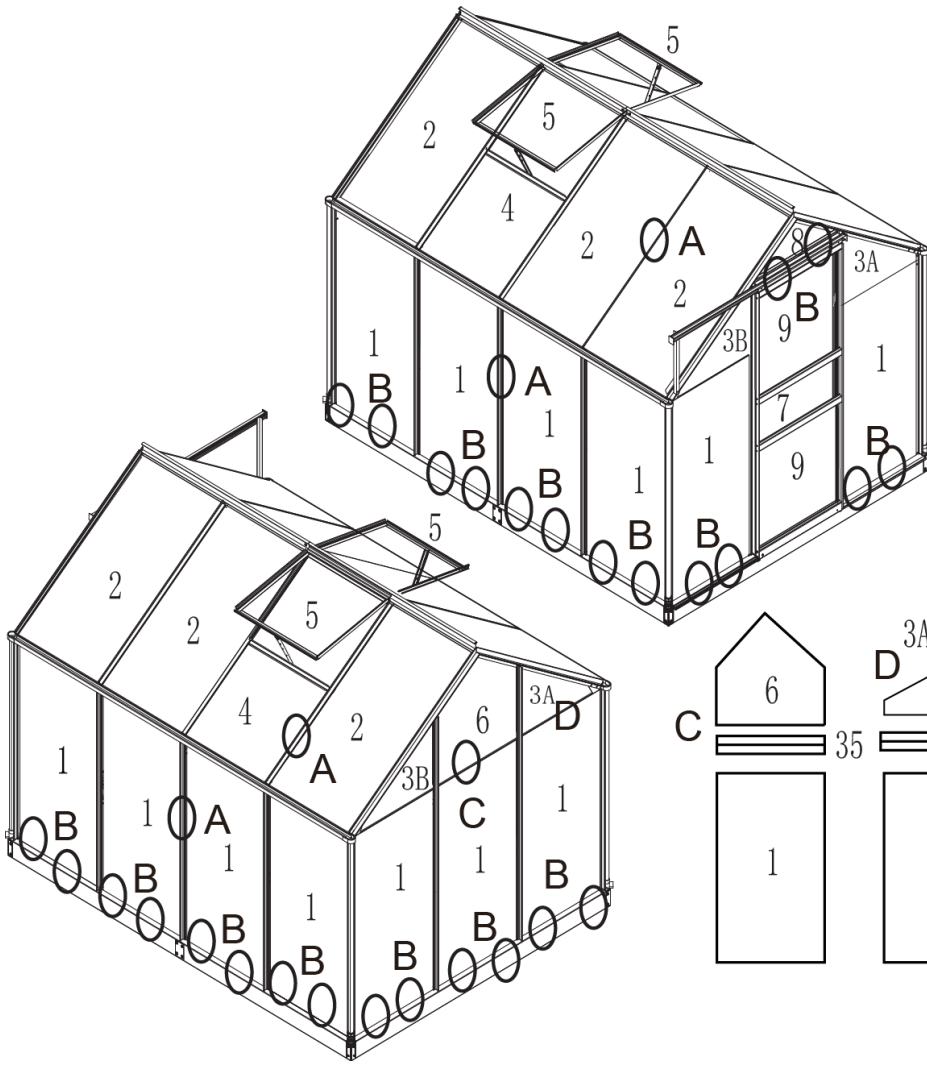

F

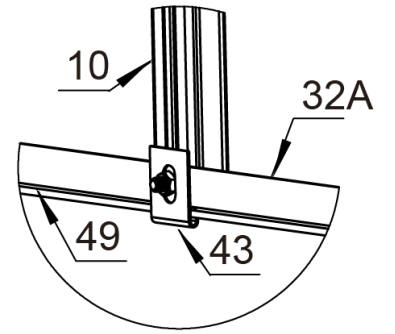

A

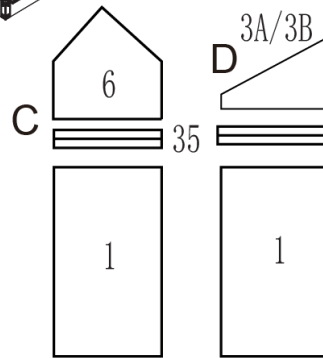
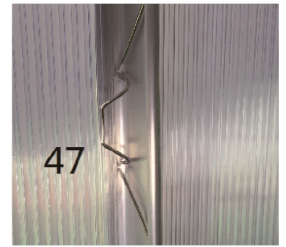



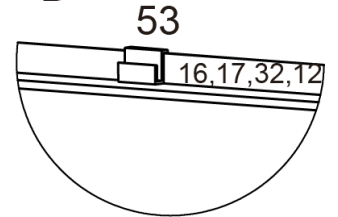

B

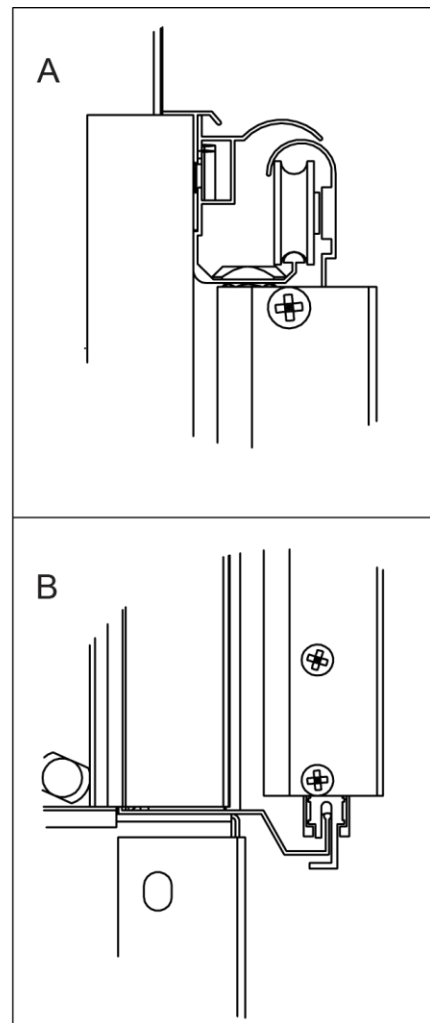
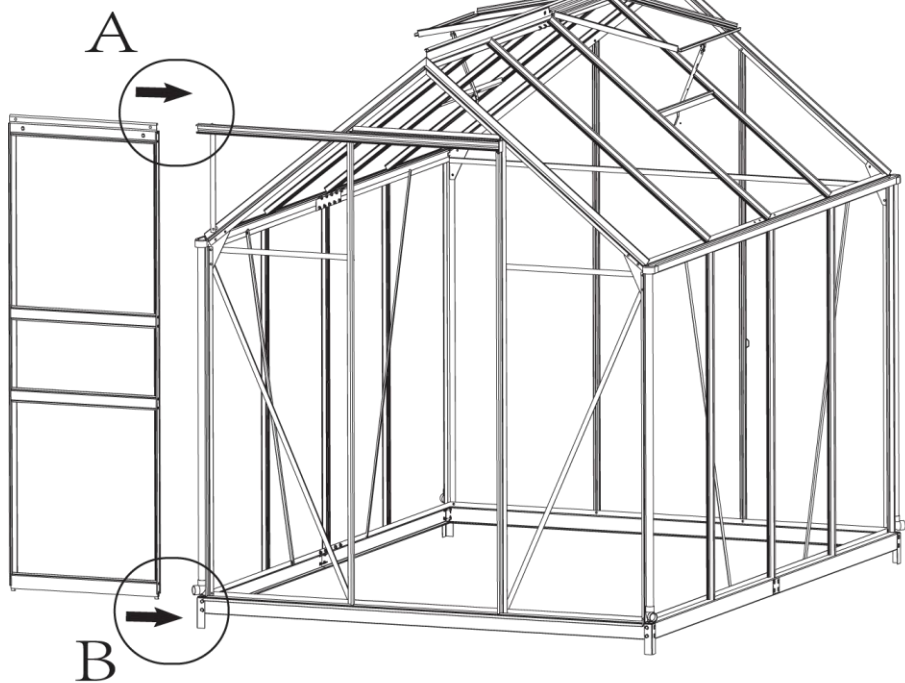

**UPEVNENIE POSUVNÝCH DVERÍ / UPEVNĚNÍ POSUVNÝCH DVEŘÍ / TOLÓAJTÓ RÖGZÍTÉSE /
FIXAREA UȘILOR GLISANTE / FIXING THE SLIDING DOOR / ANBRINGEN DER SCHIEBETÜR**

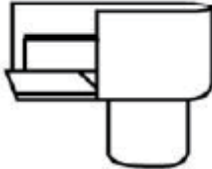
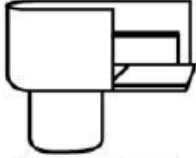

**MONTÁŽ NA ZÁKLADŇU A UPEVNIENIE ODKVAPOVÉHO ŽĽABU /
MONTÁŽ NA ZÁKLADNU A UPEVNĚNÍ ODKAPÁVACÍHO ŽLABU /
FELSZERELÉS AZ ALAPRA ÉS AZ ERESZCSATORNA RÖGZÍTÉSE /
MONTAREA PE BAZĂ ȘI FIXAREA JGHEABULUI DE SCURGERE /
MOUNTING ON BASE AND FIXING THE GUTTERING /
MONTAGE AM FUNDAMENT UND DAS FIXIEREN DER REGNRINNE**

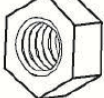
SK	Č. výr.	Obrázok	Množstvo
CZ	Č. výr.	Obrázek	Množství
HU	Cikkszám	Ábra	Mennyiség
RO	Nr. Art.	Imagine	Cantitate
EN	Product no.	Image	Quantity
DE	Art. Nr.	Abbildung	Menge
	44A		2
	44B		2
	45A		1
	45B		1
	40		2
	48		2

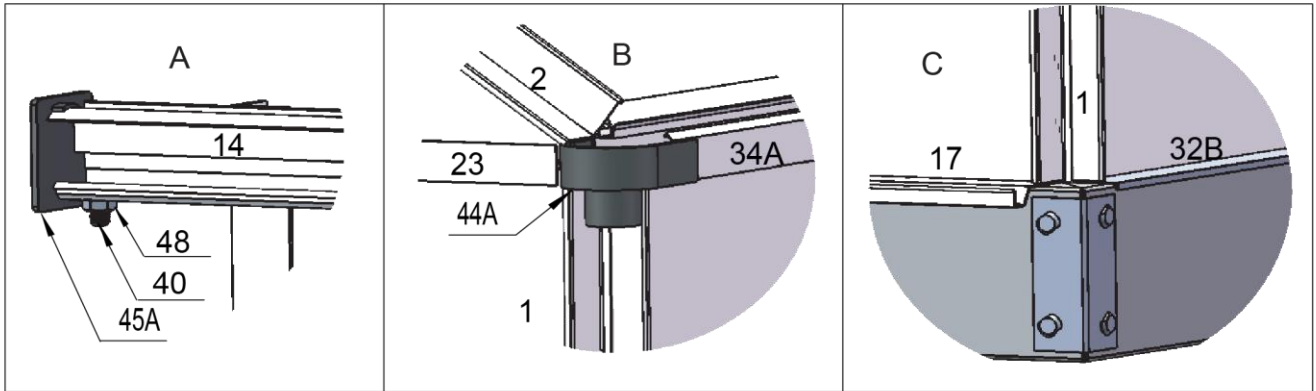
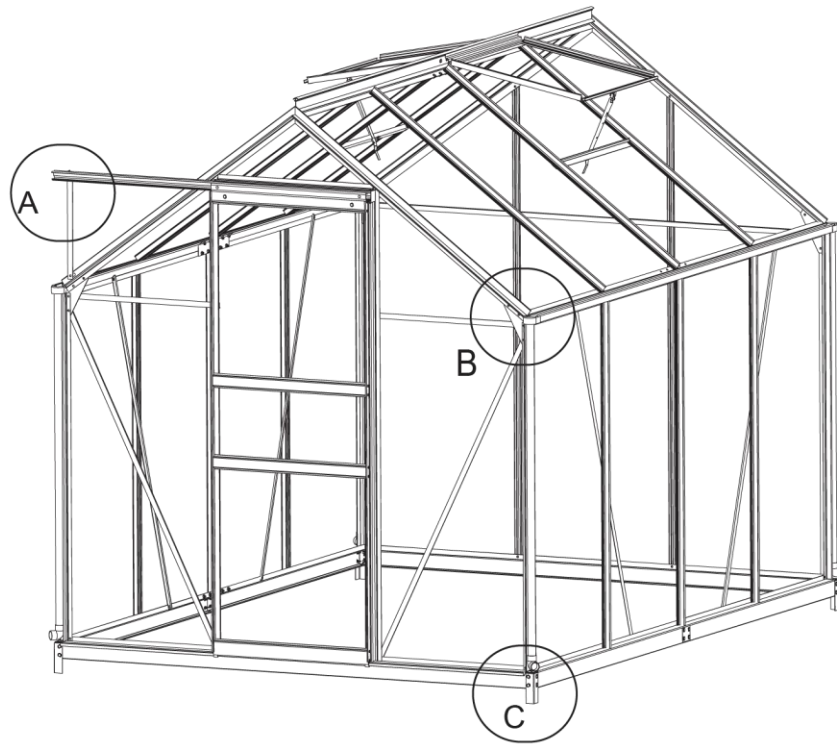



ZÁRUČNÝ LIST / ZÁRUČNÍ LIST / JÓTÁLLÁSI JEGY / LISTA DE GARANȚIE / WARRANTY LETTER / GARANTIEKARTE

Sériové číslo: Sériové číslo: Sorozatszám: Nr. serie: Serial number: Seriennummer:	Dátum predaja: Datum prodeje: Eladás dátuma: Data vânzării: Date of sale: Verkaufsdatum:	Podpis a pečiatka predajcu: Razitko a podpis prodajce: Az eladó aláírása és bélyegzője: Ștampila vânzătorului: Seller's stamp and signature: Unterschrift und Stempel des Verkäufers:

**PODMIENKY ZÁRUKY / ZÁRUČNÍ PODMÍNKY / A JÓTÁLLÁS FELTÉTELEI /
CONDIȚIILE DE GARANȚIE / WARRANTY TERMS / GARANTIEBEDINGUNGEN**

SK: Na tento výrobok sa poskytuje záruka po dobu 24 mesiacov odo dňa predaja, respektíve odo dňa vyskladnenia. V dobe záruky vám záručný servis vykoná opravy všetkých závad vzniknutých následkom výrobnéj chyby bezplatne. Pri uplatnení požiadavky na záručnú opravu musí byť spolu s prístrojom predložený úplne a čitateľne vyplnený záručný list. Pri odosielaní prístroja do opravy, dopravné náklady hradí zákazník. Originálny obal od výrobku starostlivo uschovajte.

Záruka sa nevzťahuje na

- prístroj poškodený počas dopravy a nesprávneho skladovania
- poruchy spôsobené nesprávnou obsluhou alebo údržbou
- poruchy spôsobené vplyvom opotrebenia výrobku a materiálu
- poruchy spôsobené používaním prístroja na iný účel než na aký je určený
- prístroj, do ktorého bol vykonaný neodborný zásah alebo úprava
- nekompletnosť výrobku, ktorú bolo možné zistiť už pri predaji

CZ: Na tento výrobek se poskytuje záruka po dobu 24 měsíců ode dne prodeje, respektive ode dne vyskladnění. V době záruky vám záruční servis provede opravy všech závad vzniklých následkem výrobní chyby bezplatně. Při uplatnění požadavku na záruční opravu musí být spolu s přístrojem předložen úplně a čitelně vyplněný záruční list. Při odesílání přístroje do opravy, dopravní náklady hradí zákazník. Originální obal od výrobku pečlivě uschovejte.

Záruka se nevztahuje na:

- přístroj poškozen během dopravy a nesprávného skladování
- poruchy způsobené nesprávnou obsluhou nebo údržbou
- poruchy způsobené vlivem opotřebení výrobku a materiálu
- poruchy způsobené používáním přístroje na jiný účel, než na jaký je určen
- přístroj, do kterého byl proveden neodborný zásah nebo úprava
- nekompletnost výrobku, kterou bylo možné zjistit již při prodeji

HU: Erre a termékre az eladás, illetve a kiraktározás dátumától számított 24 hónap jótállás érvényes. A jótállás időtartamán belül a garanciaszerviz Önnek ingyen biztosítja a gyártási hibából származó minden termékhiba javítását. A jótállás érvényesítéséhez a terméken kívül az olvashatóan és teljes körűen kitöltött jótállási jegy leadása is szükséges. A termék küldése esetén a szállítási költségek a vásárlót terhelik. A termék eredeti csomagolását gondosan őrizze meg.

A jótállás nem érvényes:

- ha a készülék a nem megfelelő szállítás vagy tárolás következtében hibásodott
- a helytelen használat vagy karbantartás következtében keletkező hibákra
- a termék vagy az anyag elhasználódása következtében keletkező hibákra
- a készülék nem rendeltetésszerű használata következtében keletkező hibákra
- a készülékre, amelyen nem szakszerű beavatkozást vagy módosítást hajtottak végre
- a termék hiányos voltára, amely az eladás során is már észrevehető volt

RO: Garanția pentru acest produs este 24 luni de la data vânzării, respectiv de la data scoaterii din depozit. În timpul garanției service-ul de garanție va efectua toate reparațiile de defecțiuni apărute ca urmare a greșelilor de producție, în mod gratuit. La revendicarea reparației de garanție solicitate, pe lângă produsul prezentat trebuie depusă și lista de garanție completată corect și citibil. La trimiterea aparatului la reparații, cheltuielile de transport suportă clientul. Păstrați ambalajul original al produsului cu atenție.

Garanția nu se referă la:

- aparatul defectat în timpul transportului și prin depozitare necorespunzătoare
- defecțiunile pricinuite de manipularea sau întreținerea necorespunzătoare
- defecțiunile pricinuite de uzura produsului sau materialului
- defecțiunile pricinuite de folosirea aparatului în alt scop, decât pentru care este destinat
- aparatul în care s-a intervenit sau s-a efectuat reglarea în mod necalificat
- produsul fabricat incomplet, greșeala care putea fi constatată deja la vânzare

EN: This product is guaranteed for 24 months from date of sale or removal from storage. All manufacturing defects found during the warranty period will be repaired at no charge. To submit a request for warranty repairs, fill out the warranty card legibly and completely and attach it to the device. Customers pay the cost of transport when sending a device for repairs. Keep the product's original packaging in a safe place.

The warranty does not cover:

- Damage caused to the device during transit or from improper storage
- Malfunctions caused by incorrect operation or maintenance
- Malfunctions caused by product and material wear
- Malfunctions caused by using the device for purposes other than those intended
- Damage caused by tampering or modifications
- Any incomplete work not discovered on the product when it was sold

DE: Für dieses Produkt gilt eine Garantie von 24 Monaten ab dem Verkaufsdatum oder Auslagerungsdatum. Während der Garantiezeit repariert der Garantieservice kostenlos alle Mängel, die auf einen Herstellungsfehler zurückzuführen sind. Bei Beantragung einer Garantiereparatur ist eine vollständig und leserlich ausgefüllte Garantiekarte mit dem Gerät einzureichen. Bei Einsendung des Gerätes zur Reparatur gehen die Versandkosten zu Lasten des Kunden. Bewahren Sie die Originalverpackung des Produkts sorgfältig auf.

Die Garantie erstreckt sich nicht auf:

- Beschädigungen des Gerätes durch Transport und unsachgemäße Lagerung
- Mängel, die durch falsche Bedienung oder Wartung verursacht wurden
- Mängel, die durch Abnutzung des Produkts und des Materials verursacht wurden
- Mängel, die durch zweckentfremdete Verwendung des Geräts verursacht wurden
- Geräte, die unsachgemäß behandelt oder angepasst wurden
- Unvollständigkeit des Produkts, die bereits zum Zeitpunkt des Verkaufs festgestellt werden konnte

**SERVISNÉ ZÁZNAMY / SERVISNÍ ZÁZNAMY / JAVÍTÁSI BEJEGYZÉSEK /
NOTIFICAREA SERVICE / SERVICE RECORDS / SERVICEAUFZEICHNUNGEN**

Splnomocnený zástupca výrobcu / Zplnomocnený zástupce výrobcu/ A gyártó felhatalmazott képviselője /
Reprezentantul împuternicit al producătorului: / Represented by / Hauptbevollmächtigter des Herstellers:
Slovakia Trend Export-Import s.r.o., Michalovská 87/1414, 073 01 Sobrance
Fax: (056) 652-2329 Tel: 0915 392 687 E-mail: servis@slovakia-trend.sk